

Today's Plan:

Learning Target (standard): I will describe coordinates in rectangular and polar form.

Students will: Complete practice problems over previous concepts at the boards, put up homework problems on the board and make necessary corrections to their own work, take notes over new material and complete practice problems over new concepts.

Teacher will: Provide practice problems over previous concepts, check homework problems for accuracy and provide students feedback, describe and provide examples of new concepts and assign students assessment problems over new concepts.

Assessment: Board work, homework check and homework assignment

Differentiation: Students will work at the board, go over and correct homework at their seats, actively engage in lecture over new concepts, practice new concepts with the aid of other students and the teacher and complete homework assignment.

p.576 #30-48 even

$$30)(0, -4)$$

$$32)(3, 0)$$

$$34)\left(\frac{5}{2}, -\frac{5\sqrt{3}}{2}\right)$$

$$36)\left(\frac{3}{2}, -\frac{3\sqrt{3}}{2}\right)$$

$$38)\left(\frac{3\sqrt{2}}{2}, \frac{3\sqrt{2}}{2}\right)$$

$$40)(0, 3)$$

$$42)(3.10, 0.11)$$

$$44)(3.79, -7.16)$$

$$46)\left(2, \frac{\pi}{2}\right)$$

$$48)\left(2, -\frac{\pi}{2}\right)$$

Convert the polar coordinates to rectangular coordinates. Graph the polar coordinate.

$$\left(3, \frac{\pi}{2}\right)$$

$$x = r \cos \theta$$

$$x = 3(0)$$

$$x = 0$$

$$y = r \sin \theta$$

$$y = 3(1)$$

$$y = 3$$

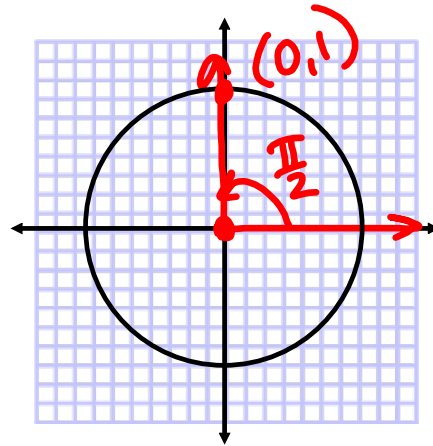

$$(0, 3)$$

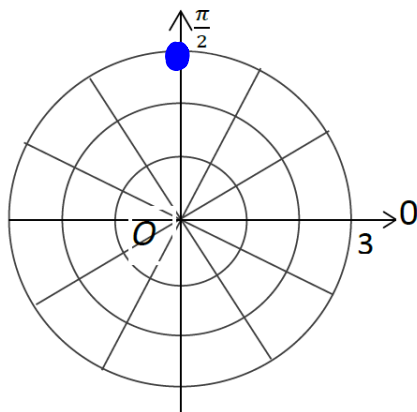

Convert the polar coordinates to rectangular coordinates. Graph the polar coordinate.

$$(6, 150^\circ)$$

$$x = r \cos \theta$$

$$x = 6\left(-\frac{\sqrt{3}}{2}\right)$$

$$x = -3\sqrt{3}$$

$$y = r \sin \theta$$

$$y = 6\left(\frac{1}{2}\right)$$

$$y = 3$$

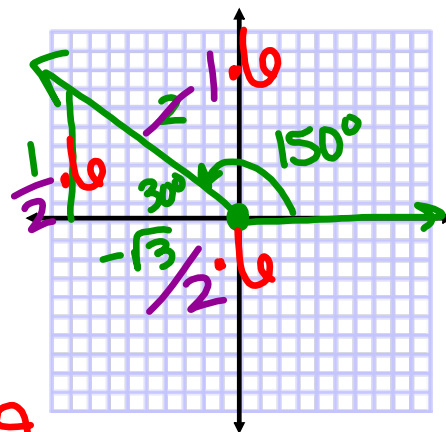

$$(-3\sqrt{3}, 3)$$

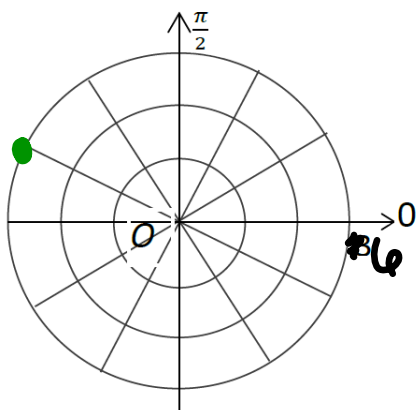

Convert the polar coordinates to rectangular coordinates. Graph the polar coordinate.

$$\left(-1, -\frac{\pi}{3}\right)$$

$$x = r \cos \theta$$

$$x = -1\left(\frac{1}{2}\right)$$

$$x = -\frac{1}{2}$$

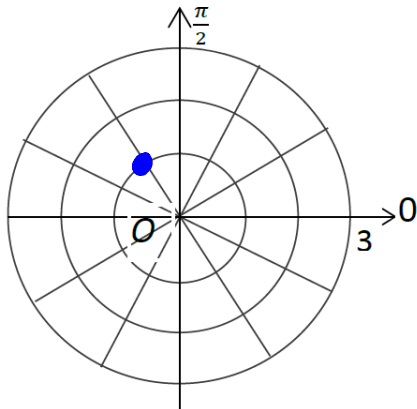
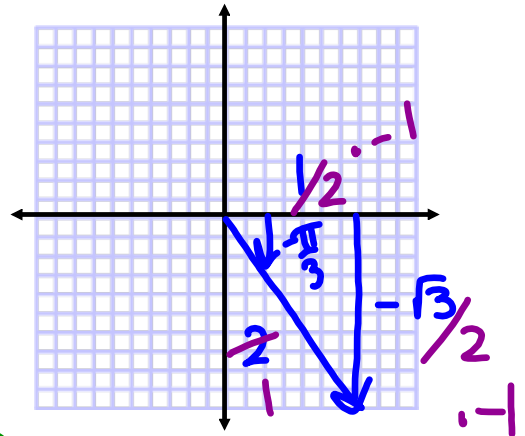

$$y = r \sin \theta$$

$$y = -1\left(-\frac{\sqrt{3}}{2}\right)$$

$$y = \frac{\sqrt{3}}{2}$$

$$\left(-\frac{1}{2}, \frac{\sqrt{3}}{2}\right)$$

Convert the polar coordinates to rectangular coordinates. Graph the polar coordinate.

$$(7.5, 110^\circ)$$

$$x = r \cos \theta$$

$$x = 7.5 \cos 110^\circ$$

$$x = -2.565$$

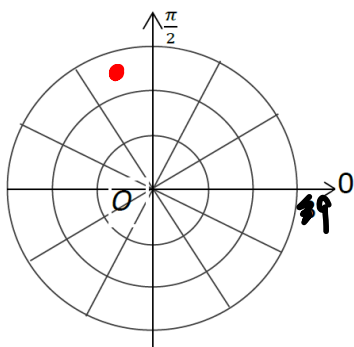
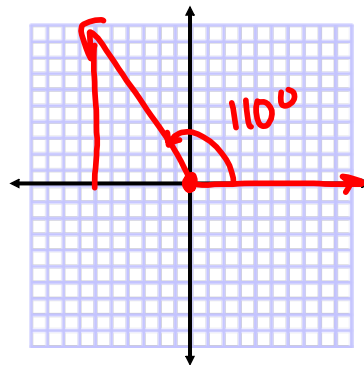

$$y = r \sin \theta$$

$$y = 7.5 \sin 110^\circ$$

$$y = 7.048$$

$$(-2.565, 7.048)$$

Convert the rectangular coordinates to polar coordinates. Graph the polar coordinate.

(3,0)

$$r^2 = x^2 + y^2$$

$$r^2 = 9 + 0$$

$$r^2 = 9$$

$$r = 3$$

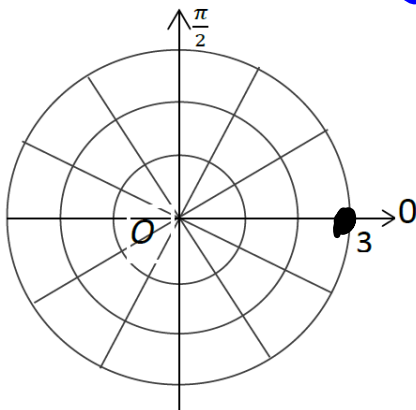
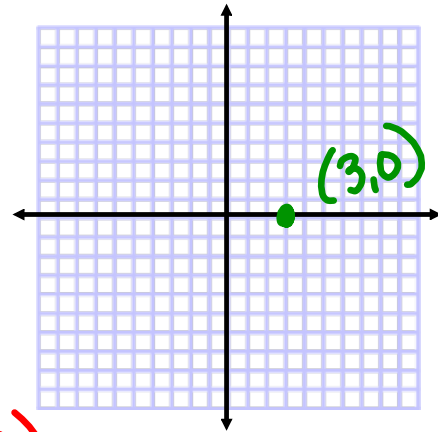

$$\tan^{-1}\left(\frac{0}{3}\right) = \theta$$

$$\theta = 0$$

$$(3, 0)$$

Convert the rectangular coordinates to polar coordinates. Graph the polar coordinate.

(1,-1)

$$r^2 = x^2 + y^2$$

$$r^2 = (1)^2 + (-1)^2$$

$$r^2 = 2$$

$$r = \sqrt{2}$$

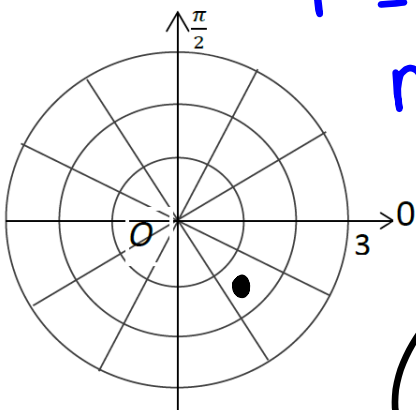
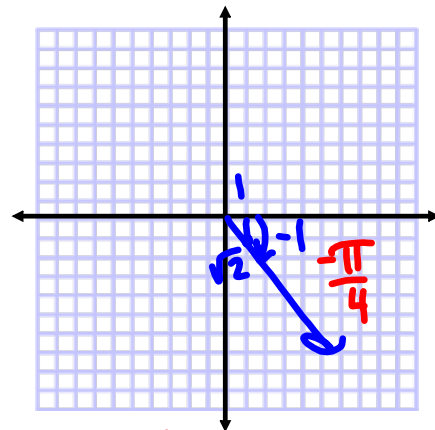

$$\tan^{-1}\left(-\frac{1}{1}\right) = \theta$$

$$\theta = -\frac{\pi}{4}$$

$$\left(\sqrt{2}, -\frac{\pi}{4}\right)$$

Convert the rectangular coordinates to polar coordinates. Graph the polar coordinate.

$$(1.3, -2.1)$$

$$r^2 = x^2 + y^2$$

$$r^2 = (1.3)^2 + (-2.1)^2$$

$$r^2 = 1.69 + 4.41$$

$$r^2 = 6.1$$

$$r = 2.470$$

$$(2.470, -1.016)$$

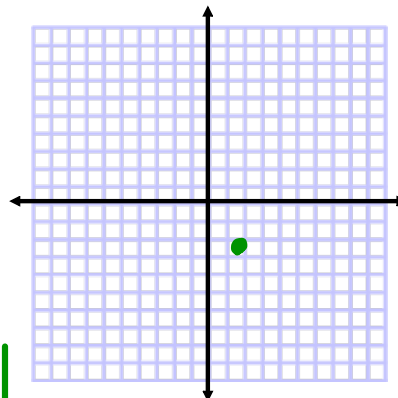

$$\tan^{-1}\left(\frac{-2.1}{1.3}\right) = \theta$$

$$\theta = -1.016$$

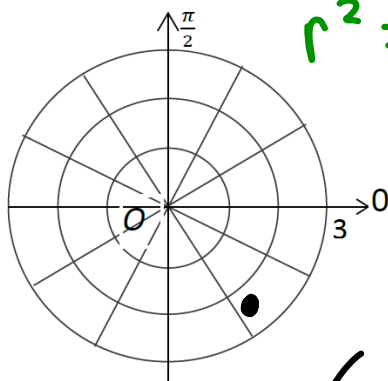

Equation Conversion from Polar Form to Rectangular Form

$$r = 4$$

$$r^2 = 16$$

$$x^2 + y^2 = 16$$

$$r^2 = x^2 + y^2$$

$$r \cos \theta = x$$

$$r \sin \theta = y$$

Equation Conversion from Polar Form to Rectangular Form

$$r = 2 \csc \theta$$

$$r = 2 \left(\frac{1}{\sin \theta} \right)$$

$$r = \frac{2}{\sin \theta}$$

$$r \sin \theta = 2$$

$$y = 2$$

Converting Equations from Rectangular to Polar Form

EX #6: Convert $(x-3)^2 + (y-2)^2 = 13$ to polar form.

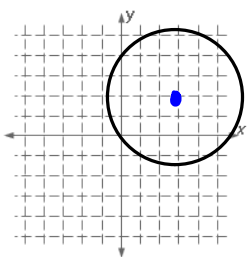

$$C: (3, 2)$$

$$r = \sqrt{13}$$

$$x^2 - 6x + 9 + y^2 - 4y + 4 = 13$$

$$\underbrace{x^2 + y^2} - \underbrace{6x} - \underbrace{4y} = 0$$

$$r^2 - 6r \cos \theta - 4r \sin \theta = 0$$

$$r^2 = 6r \cos \theta + 4r \sin \theta$$

$$r = 6 \cos \theta + 4 \sin \theta$$

Convert $r = -3 \sin \theta$ to rectangular form. Identify the graph.

$$r = -3 \sin \theta$$

$$r^2 = -3r \sin \theta$$

$$x^2 + y^2 = -3y$$

$$x^2 + y^2 + 3y = 0$$

Complete the square

$$x^2 + y^2 + 3y + \frac{9}{4} = \frac{9}{4}$$

$$x^2 + \left(y + \frac{3}{2}\right)^2 = \frac{9}{4}$$

Assignment:

p.576 #50-70 even